

Fort Belknap Community Council

(406) 353-2205
R.R. 1 Box 66
Fort Belknap Agency
Harlem, Montana 59526



Fort Belknap Indian Community
(Tribal Govt.)
Fort Belknap Indian Community
(Elected to administer the affairs of the community and
to represent the Assiniboine and the Gros Ventre
Tribes of the Fort Belknap Indian Reservation)

11/07/90

DATE

Mr. James Monteau, Superintendent
Bureau of Indian Affairs
Fort Belknap Indian Affairs
Harlem, Montana 59526

Dear Mr. Monteau

In response to the letter dated October 11, 1990, we will take responsibility of quality control. We will have on the Lake 17 Project a vibratory soil compactor. It is a Dyna Pac CA15/PDB self propelled sheep foot roller. I have enclosed the specifications on the machine. Also my grade checker is certified as a 3811-B Nuclear Densometer. He will be responsible for the compaction testing.

We will pull a material sample from the job site and will have Northern Testing run a proctor of the material.

If you have any further questions on this matter please contact me as once.

Thank You

A handwritten signature in dark ink, appearing to read "Don Werhonic". The signature is fluid and cursive.

Don Werhonic
Construction Superintendent

CC: John Allen
Ilene Wing
Boyd Johnson

Vibratory Soil Compactors

Dynapac CA15 Series

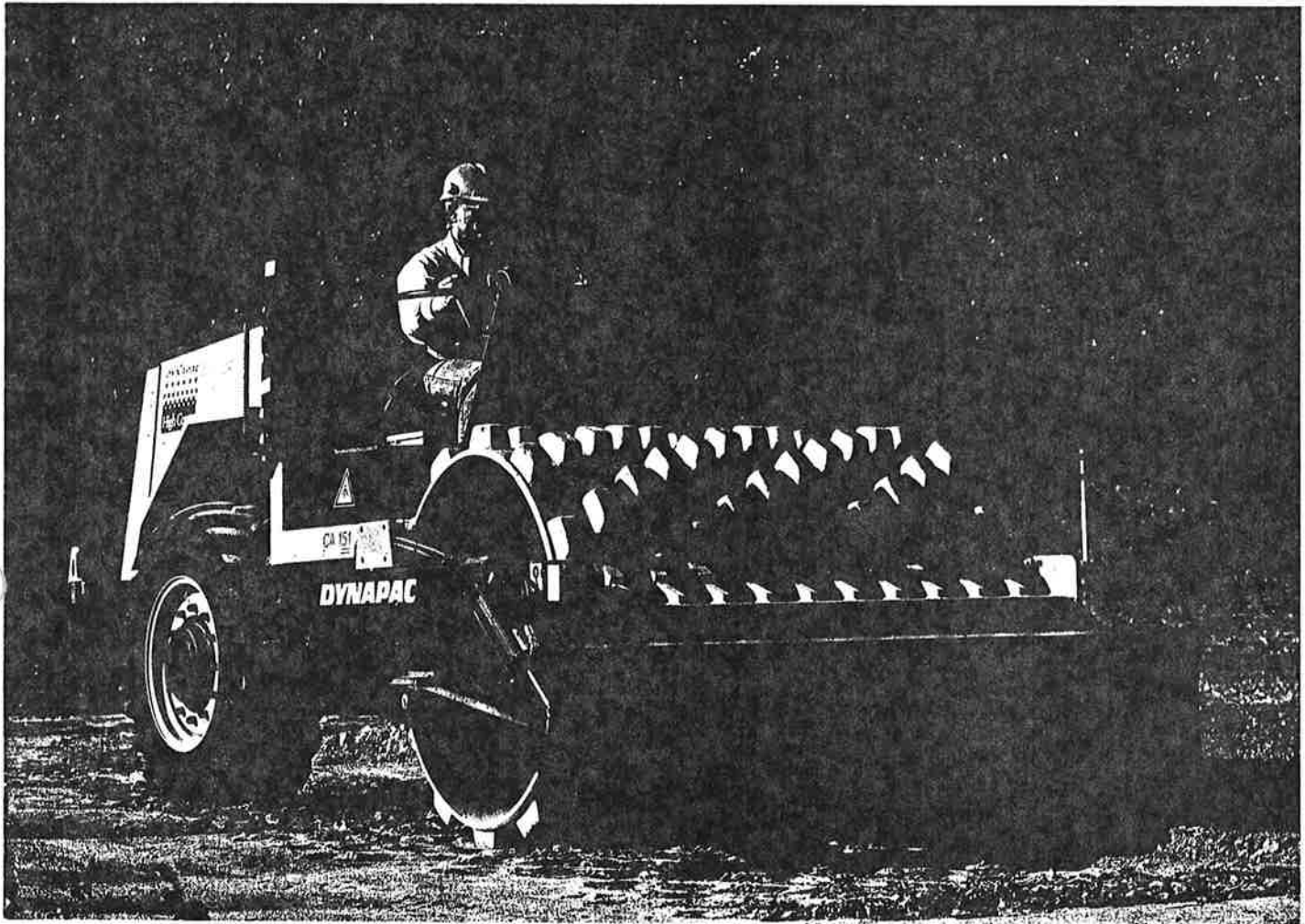

The CA15 Series vibratory soil compactors are medium volume production rollers for use on granular, semi-cohesive and cohesive soils. Each model achieves optimum density while meeting productivity requirements in a minimum number of passes. Top quality, namebrand components are used throughout to ensure minimum downtime.

Compaction

- Independent hydraulic vibration system produces optimum compaction effect.
- Direct drive eccentric weights develop the high forces necessary to speed compaction.
- Permanently lubricated shaft bearings give extended service life at high centrifugal forces.

- Interchangeable smooth and padfoot drum assemblies provide versatility to suit the application.
- Adjustable scraper bar cleans the drum in both travel directions.

Traction

- No-spin differential in the axle provides superior traction.
- Highly efficient diesel engine.
- Two-speed hydraulic transmission provides optimum working speeds.
- Hydrostatic/planetary torque hub drive in parallel with the wheel drive for additional traction (drum drive models).

Maneuverability

- Articulated center-point hydraulic steering provides easy handling and a short turning radius.

- Vertically oscillating steering assembly permits operation over rough terrain.

Owner/Operator Benefits

- Specially engineered shock absorber systems, isolate the operator platform from vibration.
- Two independent braking systems — service braking is located at the forward/reverse lever — failsafe multi-disc parking brake in the rear axle automatically activates in the event of a hydraulic system failure.
- Large fuel tank permits working a full shift.
- Lockable swing-up engine covers, hydraulically-assisted and vandal-resistant, protect maintenance points and give easy service access.

ROPS and seat belts are STRONGLY RECOMMENDED at all times.

Specifications

General	CA151	CA151D	CA151PD	CA151PDB	STANDARD INSTRUMENTATION • Voltmeter • Tachometer • Hourmeter • Fuel Gauge • Hydraulic Oil Temperature Gauge • Water Temperature Gauge • Air Cleaner Warning Light • Oil Pressure Light • Brake Warning Light.
Shipping Weight	lbs 13,780	14,000	15,100	15,980	
Operating Weight	lbs 14,000	14,220	15,320	16,200	
Drum Module Weight	lbs 7,805	7,305	8,405	9,285	
Tractor Module Weight	lbs 6,915	6,915	6,915	6,915	
Compaction Characteristics					
Type	Direct drive hydraulic motor, control at operator station.				
Vibration Frequency HI	vpm 1,740	1,740	1,740	1,740	
LO	vpm 2,400	2,400	—	—	
Centrifugal Force HI	lbs/pli 22,500/341	22,500/341	27,900	27,900	
LO	lbs/pli 20,925/317	20,925/317	—	—	
Nominal Amplitude HI	in .083	.083	.087	.087	
LO	in .032	.032	—	—	
Number of Pads	—	—	132	132	
Static Force	pli 107	111	—	—	
Propulsion Characteristics					
Type	Hydrostatic with two-speed transmission to planetary no-spin axle. D, PD and PDB models have drum drive.				
Engine	Cummins 4BT3.9, 98 hp @ 2,400 rpm.				
Speed Range	mph 0-5	0-3	0-3	0-3	
	mph 0-11	0-4.5	0-4.5	0-4.5	
Gradability*	% 48	65	65	65	
Fuel Tank Capacity	gal 49	48	48	49	
Tires	14.9 x 24 8-ply	14.9 x 24 6-ply	14.9 x 24 6-ply	14.9 x 24 6-ply	
Steering Characteristics					
Type	Hydraulic, center-point articulated.				
Vertical Oscillation	degrees ±9	±9	±9	±9	
Steering Angle	degrees ±38	±38	±38	±38	
Braking Characteristics					
Service:	Hydrostatic at forward/reverse lever.				
Emergency/Parking:	Failsafe, multi-disc on rear axle.				
Dimensional Data					
	CA151	CA151D	CA151PD	CA151PDB	
A	in 186	186	190	207	
B	in 74	74	74	74	
C	in 77	77	80	80	
C'	in 112	112	113	113	
C''	in 104	104	106	106	
D	in 48	48	48	48	
E	in 66	66	66	66	
F	in 100	100	100	100	
G	in 12	12	15	15	
H	in 65	65	65	65	
I	in —	—	3	3	
J	in ¾	¾	¾	¾	
K	in —	—	—	88	
L	in —	—	—	23	
M	in —	—	—	17	
N	in —	—	—	3	
O	in —	—	—	21	
P	in 157	157	157	157	
Q	in 91	91	91	91	

* Gradability is determined by traction and the rolling resistance of the material.

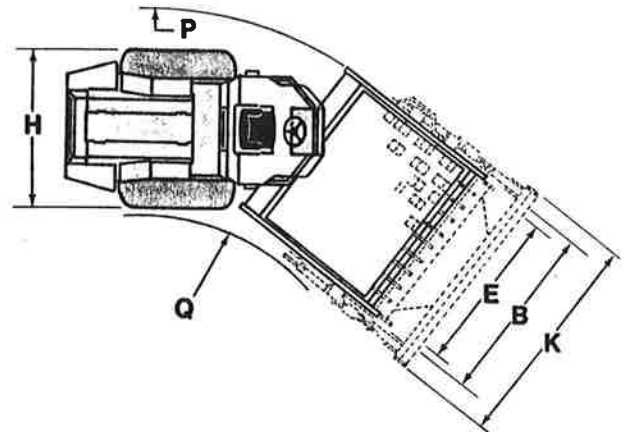
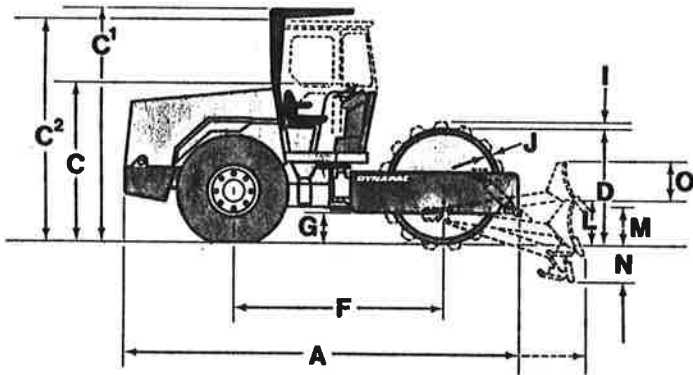

DYNAPAC

Dynapac Headquarters
699 Washington Street
Hackettstown, NJ 07840
Phone: 201-850-1200
Telefax: 201-850-6113

Dynapac West
131 East Fig Street, Suite 7
Fallbrook, CA 92028
Phone: 619-728-3117
Telefax: 619-728-4602

Dynapac Central
3805 Farhills Drive
Champaign, IL 61821
Phone: 217-398-2230
Telefax: 217-398-2244

Dynapac East
689 Washington Street
Hackettstown, NJ 07840
Phone: 201-850-5115
Telefax: 201-850-3760

Dynapac South
7254 Northwest 31st Street
Miami, FL 33122
Phone: 305-594-1148
Telefax: 305-594-4563

Your Local Contact:

HALL PERRY
1215 38th St. No.
P O Box 2066
Great Falls, MT 59403
1-800-823-3337

Vibratory Asphalt Rollers

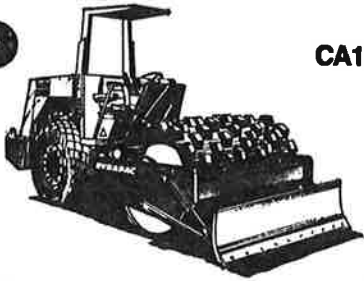

CA151PDB

Medium production • Moist sub-soils • Colloidal soils
Large trenches • Road sub-soils • Foundation sub-soils
Embankment slopes.

CA251PDB

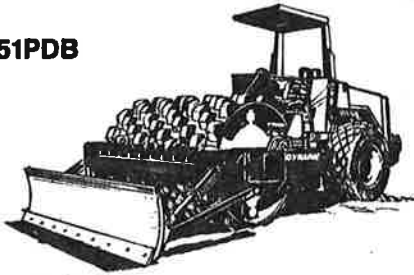

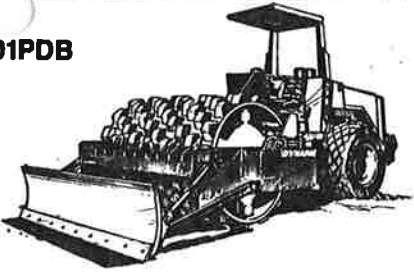

Medium production soils • Moist sub-grade soils
Colloidal materials • Cohesive soils
Embankments • Major highway sub-soils
Airport sub-soils • Dams (impervious till).

CA301PDB

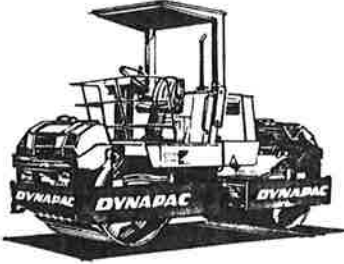

Medium-high production • Embankments
Granular, cohesive and semi-cohesive materials
Highways • Industrial foundations
Airport runways.

ROPS and seat belts are STRONGLY RECOMMENDED for use in hazardous conditions.

<p>Asphalt</p> <ul style="list-style-type: none"> • City and municipal streets • Airport runways • Primary highways/interstates • Large overlays • Heater planer compaction. <p>Soil</p> <ul style="list-style-type: none"> • Stabilized base • Certain sand bases • In-place recycled materials • Smaller airport runway bases • Primary and secondary highway base. 	<p>CC211</p> 
<p>Asphalt</p> <ul style="list-style-type: none"> • City and municipal roads and streets • Overlays • Industrial parking lots • Entrance and exit ramps • Secondary roller—high tonnage jobs • Interstate shoulders • Airport maintenance. <p>Soil</p> <ul style="list-style-type: none"> • Stabilized base • Industrial foundations • Secondary road base • Airport maintenance (light) • Major urban base construction repairs. 	<p>CC421</p> 
<p>Asphalt</p> <ul style="list-style-type: none"> • Major highway/runway construction • Deep lift overlays • High surface volume • High density requirements • Cold in-place mixes. <p>Soil</p> <ul style="list-style-type: none"> • Cement stabilized base • Roller compacted concrete • Airport runway construction • Most fine base materials 	<p>CC501</p> 

ASPHALT ROLLERS			
CC211	CC421	CC501	Operating Weight (lbs)
15,210	21,720	32,630	Centrifugal Force Hl (lbs)
15,075	27,675	42,075	Centrifugal Force Lo (lbs)
8,550	13,500	21,150	Vibration Frequency (vpm)
2,820	2,820	2,700	Drum Diameter (in)
41	48	60	Drum Width (in)
57	66	84	Diesel Horsepower
72	123	210	